

Monster AGTT

There is no place for risk
and fatigue in the future

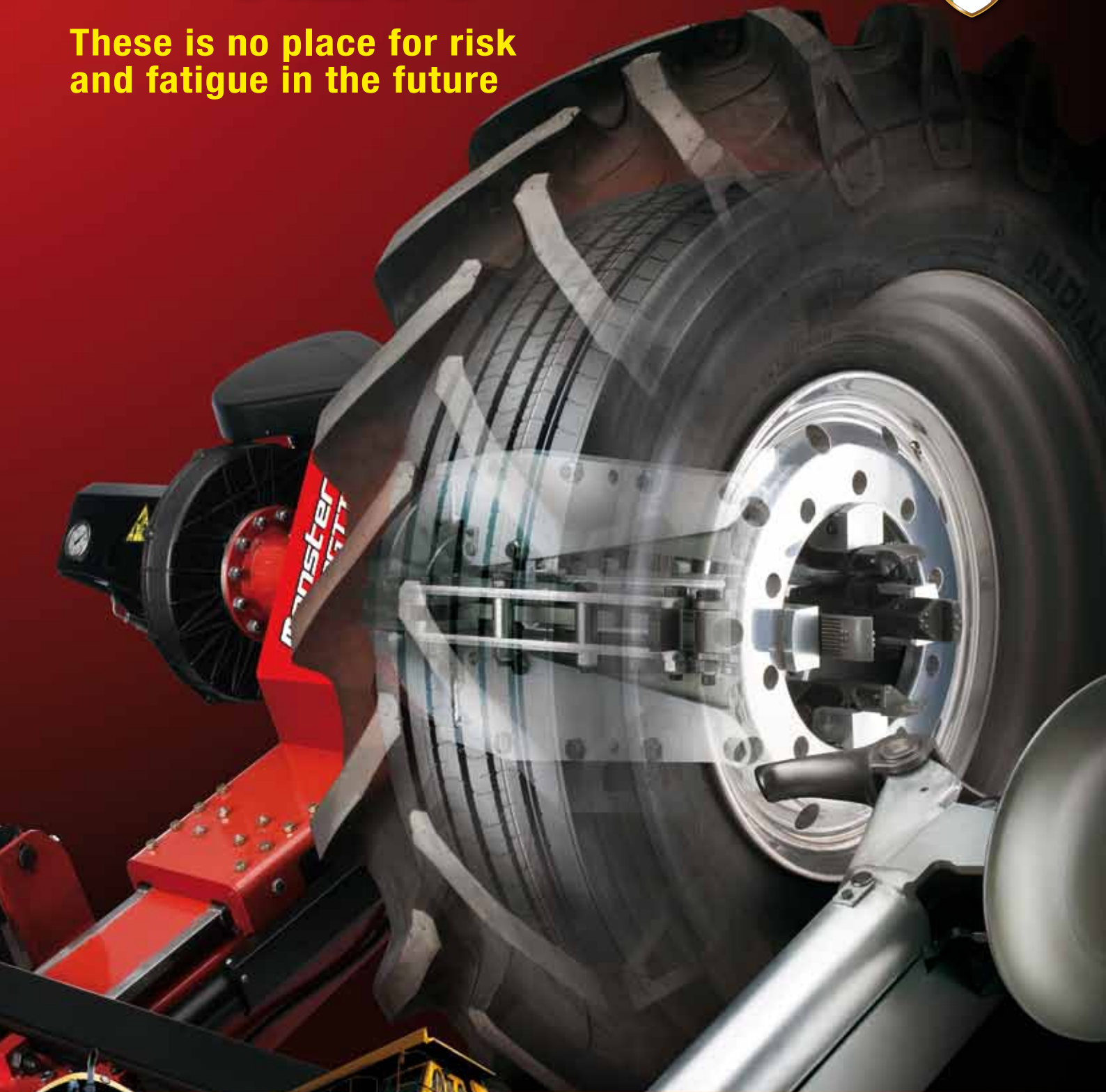

TECHNOLOGY
PARTNER
product



 **CORCHI**

Segui Corghi - Follow Corghi

**Monster
AGTT**

A close-up photograph of a motorcycle handlebar grip. The grip is black and mounted on a silver metal handlebar. A red dashed line forms a circle around the grip and extends upwards to a red rounded rectangle containing the brand name. Another red dashed line forms a circle around the grip and extends to the right, framing a red text box. The text box contains the text 'The only one in the world with 'leva la leva' (without lever) technology' with a red arrow pointing to the base of the grip.

**The only one
in the world
with 'leva la leva'
(without lever)
technology**

A “performance monster” for professionals operating in the industrial tyre sector

Corghi, a leading tyre changer manufacturer with an in-depth knowledge of the problems faced by the industry, has opened up a new frontier for professionals operating in the heavy tyres sector. In response to the pressing demands of **tyre repairers specializing in trucks, earth moving machinery, and agricultural machinery**, as well as those operating in **transport fleet service shops**, **Corghi's** researchers have developed and patented a new and revolutionary heavy duty tyre changer.



In addition to featuring the most advanced technologies, the **Monster AG TT** also embodies all the characteristics necessary to render it an essential and irreplaceable tool in terms of quality and operator safety in the industrial tyre sector.

Major advantages in 5 strengths:

- 1 Significant reduction in fatigue
- 2 Exceptional protection for rims and tyres
- 3 High performance
- 4 Maximum safety
- 5 Completely universal

As of today, with the **Monster AG TT**, the specialized tyre repair profession has changed considerably, offering greater **efficiency, speed and service quality** to operators and customers alike.



1 Significant reduction in fatigue

The **Monster AG TT** is a **super-automatic** and **revolutionary** tyre changer. It's the world's only tyre changer to be equipped with a "**Leva la Leva**" (without lever) in order to significantly reduce the fatigue and risks posed to professionals specializing in the demounting of all types of wheels: trucks, buses, agricultural vehicles, and earth moving machinery. Equipped with an automatic wheel clamping device and **turntable** (without the use of extensions), the **Monster AG TT** features an electronic system for memorizing the rim diameter and wheel position, as well as a "Side to Side" device, which allows the tools to be automatically transferred from one side of the tyre to the other.

2 Exceptional protection for rims and tyres

The entire tool holder block is **hydraulically operated**. It includes the "**Leva la Leva**" (without lever) for demounting the tyre in an entirely automated manner, as well as a special **bead breaker disc**, which ensures the **perfect tilt** throughout every stage of the operations, based on the hydraulic movement. One of the system's essential features is the arm that controls the tool holder block, which always maintains a **perfect tangency between the wheel and the tools** by coordinating its movements with the turntable. This helps to **reduce tension** and **avoid unnecessary contacts**, thus ensuring maximum protection **for the integrity of the rims and tyres**.

3 High performance

The **Monster AG TT** has been designed and built to ensure maximum flexibility and functionality for the operator. The **tool block's single position** on the trolley renders the work operations quicker and easier; the new play recovery slides allow for any play caused by wear to be eliminated; the **function for memorizing** the position of the tools expedites positioning during mounting and demounting operations, while the **synchronized handling** of the spindle and the tool trolley, the **electro-hydraulic power unit with a user adjustable display**, and the possibility of automatically positioning both the hook and the disc in tangency with the rim, render the **Monster AG TT** an irreplaceable and one-of-a-kind unit.

4 Maximum safety

In addition to reducing fatigue, the **Monster AG TT** has also been designed to ensure maximum protection and safety for the operator. The tyre changer's design excludes the need for a base, thus resulting in the elimination of any height offsets, which can certainly be hazardous when loading **large and heavy** wheels.

This design feature allows the operator to work under conditions of **complete safety**, with the wheel raised off the ground by just a **few centimetres**.

What's more, the **new manipulator with ergonomic controls** allows for all the operations to be controlled without ever coming into contact with the tool block.

5 Completely universal

The **Monster AG TT** unit's universal nature is ensured by the new **turntable** clamping system, which consists of **tilting claws with 9 direct clamping positions**, from **14"** to **48"**, and up to **58"** with tilting. The system is predisposed to clamp rims with a minimum hole size of **90 mm**. The turntable is equipped with a **moto inverter**, which allows for the **optimal speed** to be automatically **obtained** for each individual operation, including **tyre grooving** operations.



Electro-hydraulic power unit



"Leva la Leva" (without lever)

Turntable clamp

Bead breaker disc

Radio-transmitting control unit

Corghi research and experience, for an unsurpassable product



The new and exclusive **tilting claw** ensures complete **adaptability to every type of rim**.

From **90 mm** to **58"**, the **Monster AG TT** can be used for the tyres of any type of motorized vehicle.

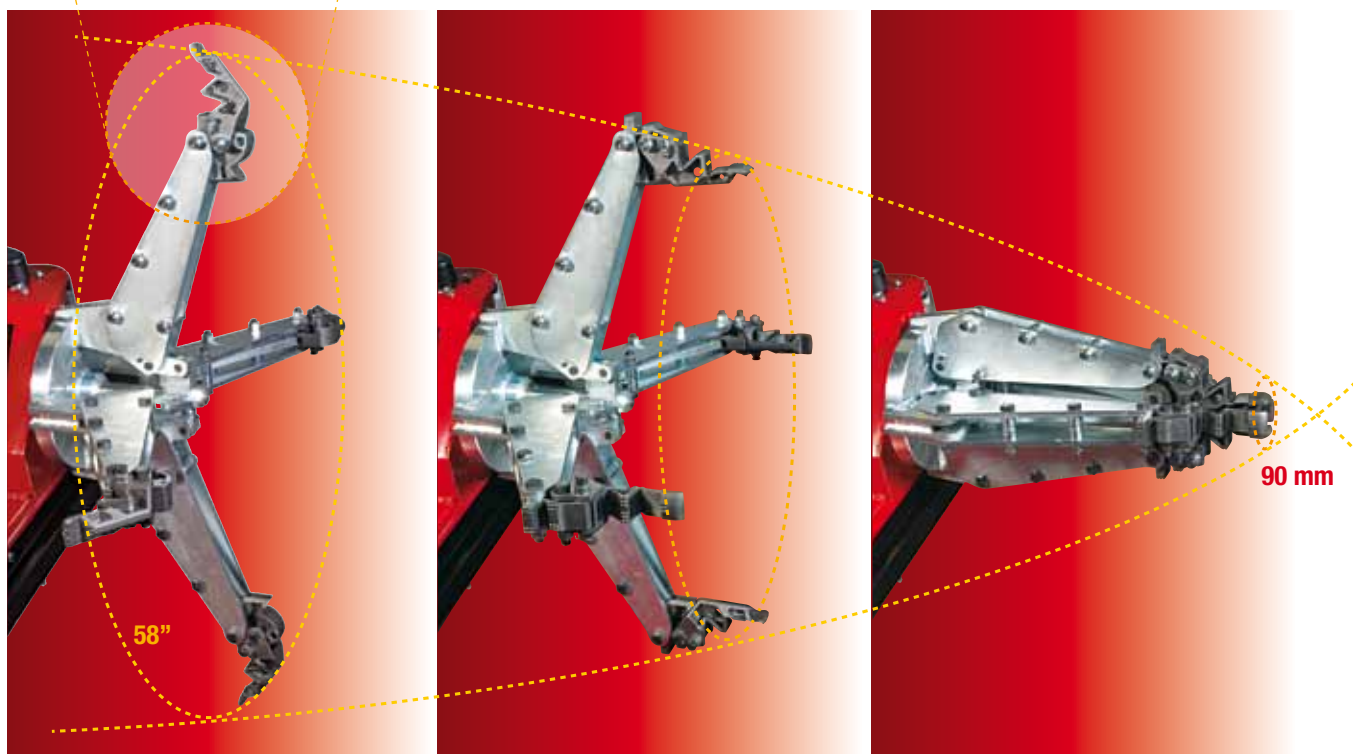

The **S.T.S. (Side To Side)** device allows for the tool block to be **automatically transferred** from one side of the tyre to the other



The **new manipulator** with **ergonomic** controls ensures the tyre changer's complete functionality, with no need for the operator to **come into contact with the tools**.

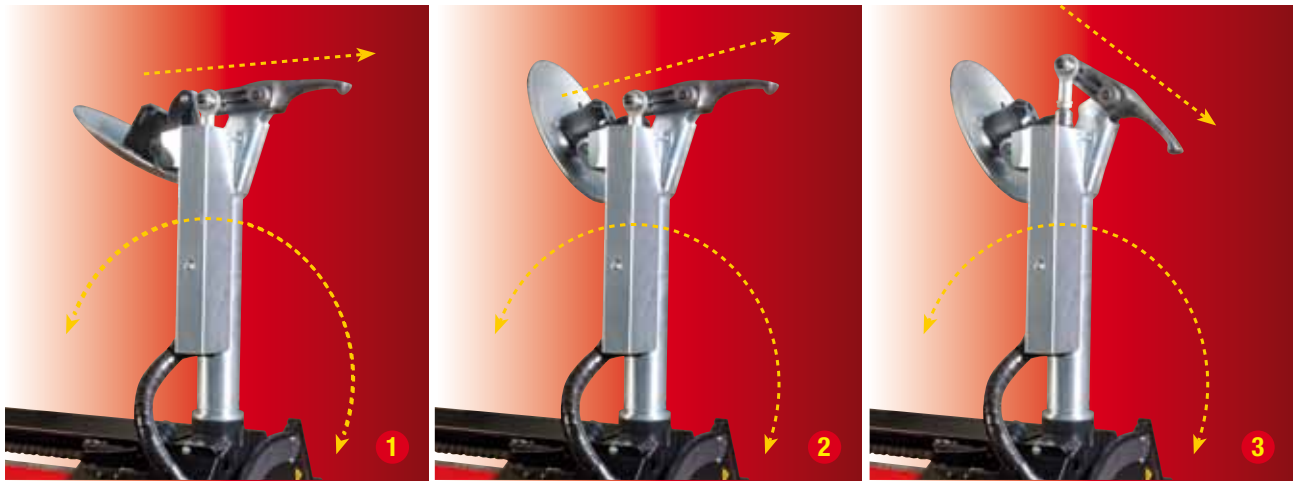

Tool's sequence of automatic movements:

- 1 bead connection 2 position for rim tangency 3 "Leva la Leva" (without lever) demounting position



Bead breaker disc sequence of automatic movements:

- 1 disc in tangency with the rim (minimum tilt) 2 disc tiltable to maximum tilt 3 tool unit rotation



The ergonomic control unit with wheels (trolley-style) is separate from the machine, and is designed to facilitate the operator's work.



The electro-hydraulic power unit with display can be positioned as desired and allows the user to **save all the data** relating to the tyre being processed.

**Monster
AGTT**

Starting today no more levers, no more fatigue, no more damage to rims or tyres, and no more risks for the operator.

Technical data

Tool arm	
Demounting type	"Leva la Leva" (without lever)
Type of tool-rim tangency	YES
Automatic wheel side change movement "S.T.S"	YES
Bead breaker disc	with "patented" hydraulic movement
Axial stroke	1,120 mm
Axial travel speed	100 mm/s 40 mm/s
Max. axial bead breaking force on the inside	30,000 N
Max axial bead breaking force on the outside	25,000 N
Rotation	hydraulic
Clamping	hydraulic
Tool arm lifting	hydraulic
Spindle support trolley	
Axial hydraulic stroke	670mm
Axial working speed	70 mm/s
Spindle	
Clamping system	hydraulic turntable
Rotation motor	inverter motor
Rotational speed	3-speeds 1 - 3.5 - 7.8 RPM
Max. rotation torque	5,500 Nm
Clamping element	4 "patented" tilting (claws)
Clamping capacity	from 14" to 58"
Clamping positions	9
Maximum clamping force	40,000 N
Maximum hydraulic pressure	180 bar
Maximum tyre diameter	2,500 mm
Maximum tyre width	1,600 mm
Maximum wheel weight	liftable: 2,500 kg working: 1,700 kg
Wheel central hole minimum Ø	90 mm
Minimum turntable shaft working height	450 mm
Base	
Wheel loading zone	floor level
Hydraulic control unit - electric system	
Stand-by function	YES
Wheel inches display setting	YES
Operation	Electric
Motor	3.3 - 4 kW
Adjustable hydraulic pressure	from 80 to 180 bar
Oil tank	15 l
Power supply	Electric 3ph 230/400 V - 5 kW
Noise level during operation	63dB(A)
Control module	
Command transmission	via radio
Emergency button	YES
Electrical voltage	24V
Weight	8kg
Dimensions	
Length	2,400 mm
Width	2,200 mm
Maximum height	1,800 mm
Maximum wheel weight	1,700 kg

